



HARDY

HANN KUEN MACHINERY&HARDWARE

http://www.hardy-tw.com

TEL : 886-4-24860602

FAX : 886-4-24860605

S,SR Boring&Milling Head Unit

SD Drilling Head Unit

ST Tapping Head Unit

Order Form

| | | | |
|---------|--|--------------|--|
| Company | | Contact With | |
| Tel | | Fax | |
| Address | | | |

I . Model: _____ Spindle Taper _____ Quantity _____

II . Propel: Pneumatic Hydraulic Servo Motor / Draw Bar: Metric Inch

III . Cutting: Drilling Tapping Boring Milling Other _____

IV . Cutting Material: _____ Diameter _____ ϕ Depth _____ RPM _____

Tap Pitch _____ Cutter Material: High Speed Steel Carbide Tip

V . Spindle Motor: 3-Phase AC Induction Gear Reducer Servo Motor

_____HP (kW) _____P (Pole) _____V (Voltage) _____Hz (Frequency)

VI . Feeding Servo Motor: _____kW _____V (drawing required)

VII . Facing Head Servo Motor: _____kW _____V (drawing required)

VIII . Transmission: Timing Belt V Belt Poly-V Belt Other _____

IX . Accessories: Motor Stand Motor Plates Motor with brake Guide Rod

Limit Switch Proximity Sensor

Left Fluid Control _____ pcs

Left Limit Switch or Proximity Sensor _____ pcs

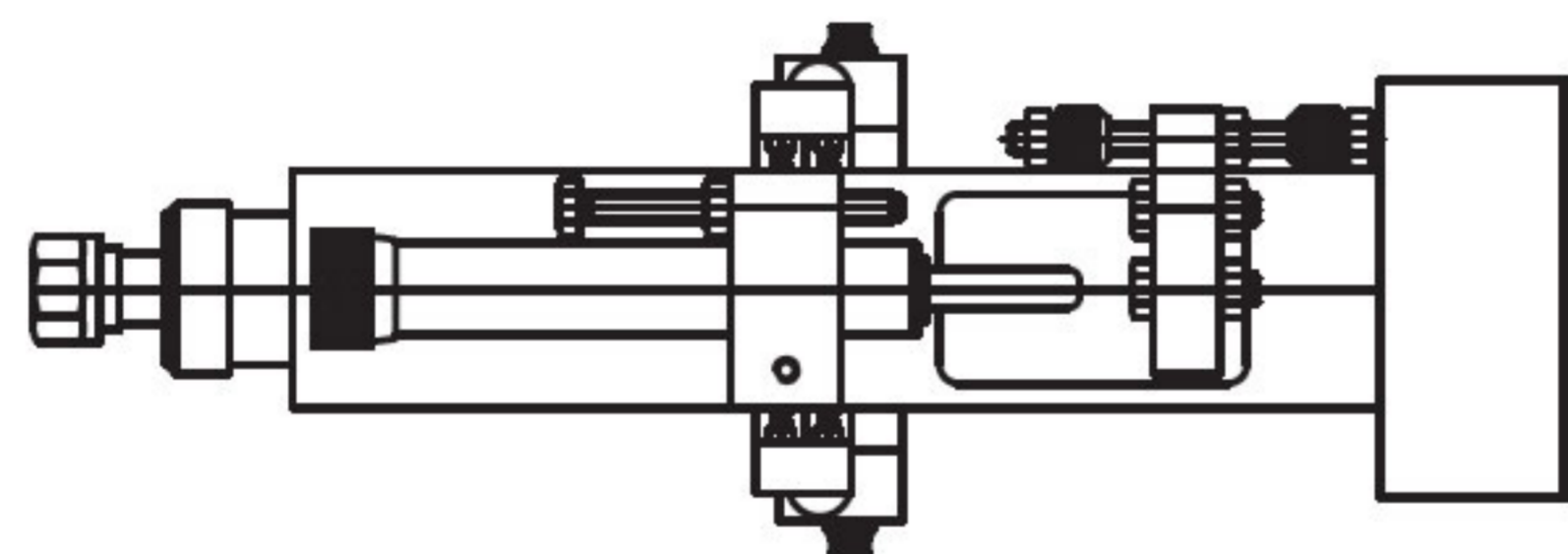

Right Fluid Control _____ pcs

Right Limit Switch or Proximity Sensor _____ pcs

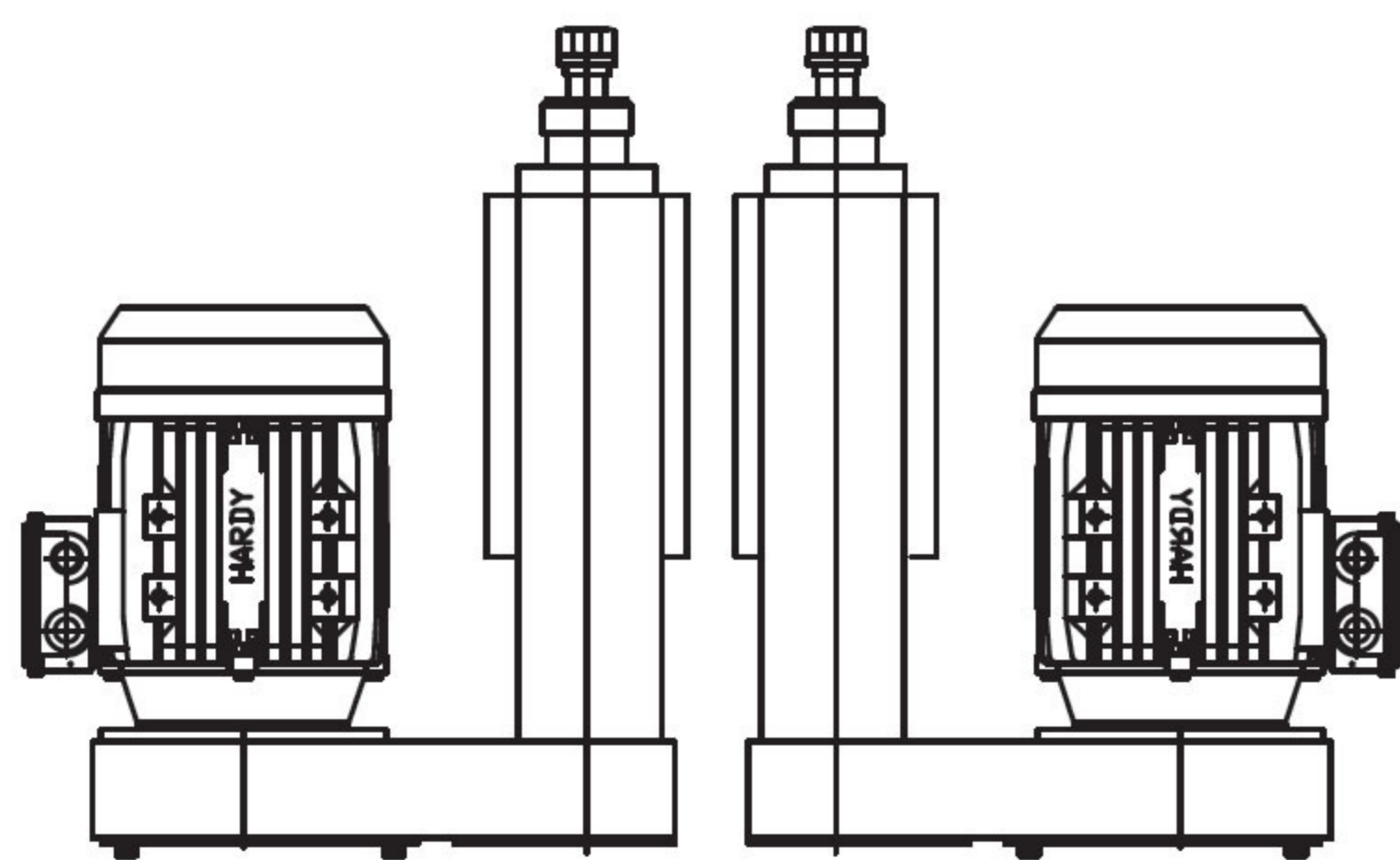

Right90° Front _____ pcs

Back _____ pcs

Left90° Front _____ pcs

Back _____ pcs

Motor Direction

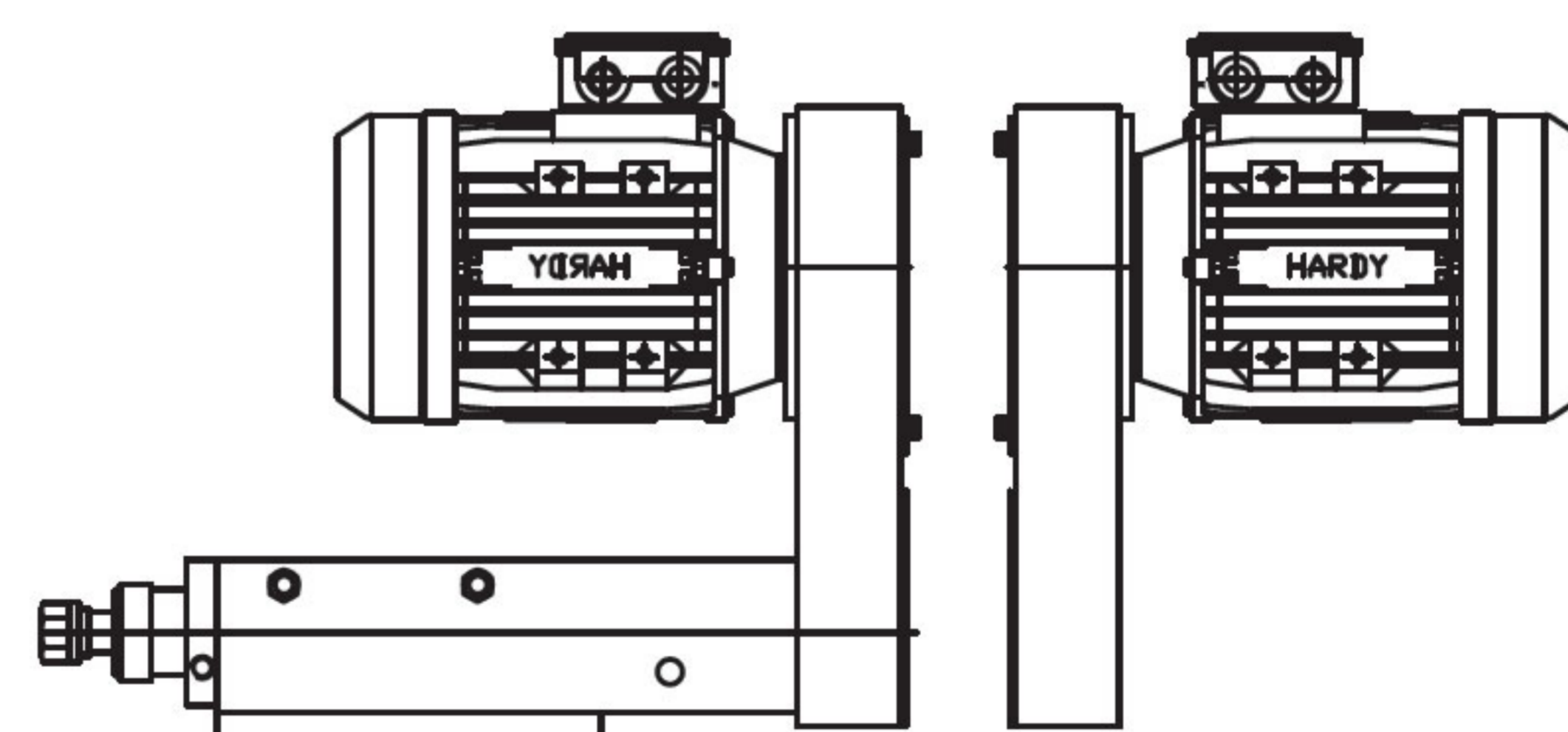

Upside, Front _____ pcs

Upside, Back _____ pcs

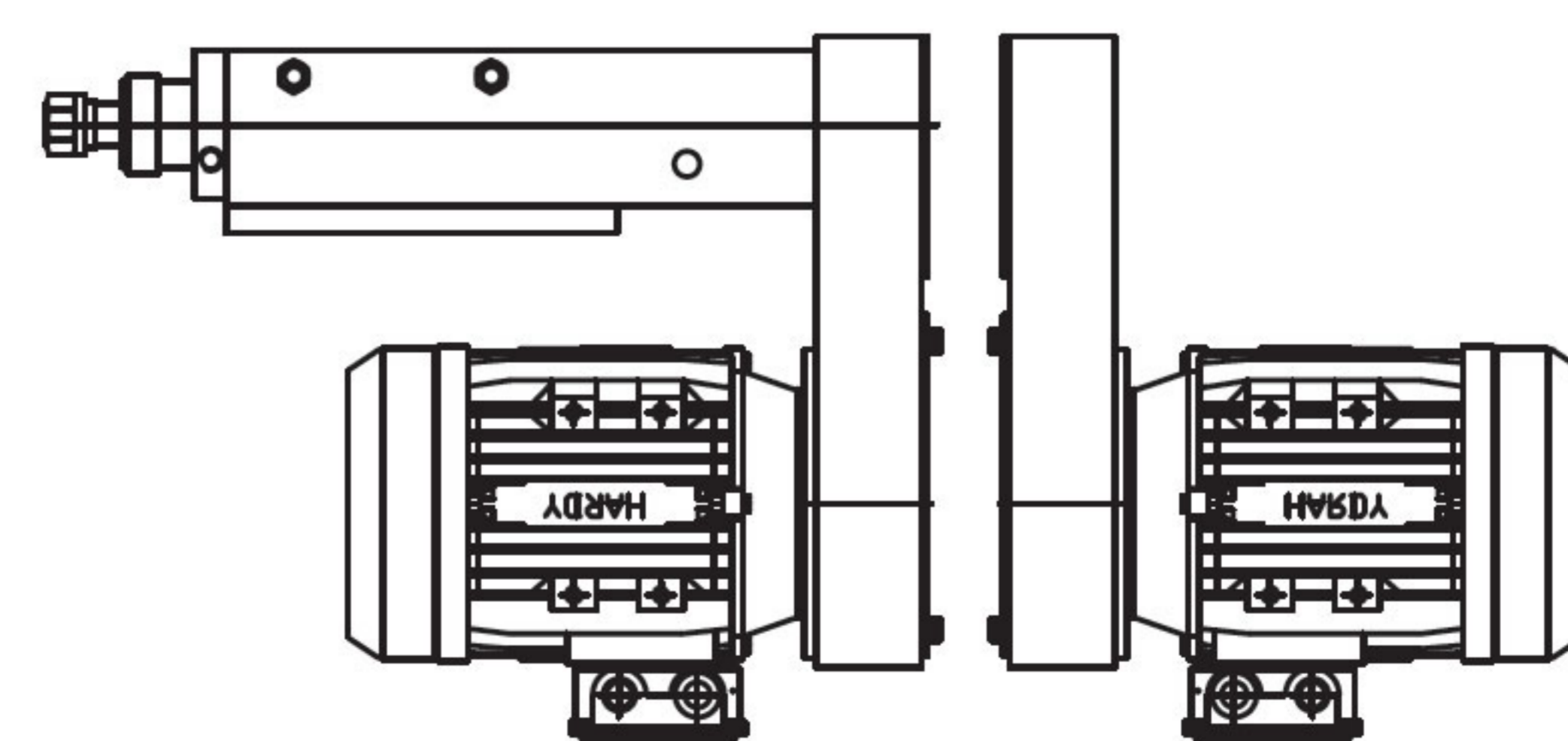

Bottom, Front _____ pcs

Bottom, Back _____ pcs



HANN KUEN MACHINERY&HARDWARE
 http://www.hardy-tw.com
 TEL : 886-4-24860602
 FAX : 886-4-24860605

- RH Servo with Ball Screws Slide
- BS Servo with Ball Screws Slide
- LS Lead Screw Slide
- HS Hydraulic Slide Unit

HARDY

Order Form

| | | | |
|---------|--|--------------|--|
| Company | | Contact With | |
| Tel | | Fax | |
| Address | | | |

I \ Model :

| | | | | |
|------------------------------------------------|----------------------|----------------------|----------------------|----------------------|
| <input type="checkbox"/> RH Ball Screw | Up Plate-W × L | Height H | Travel L | Quantity |
| <input type="checkbox"/> BS Ball Screw | <input type="text"/> | <input type="text"/> | <input type="text"/> | <input type="text"/> |
| <input type="checkbox"/> HS Hydraulic Cylinder | <input type="text"/> | | | |
| <input type="checkbox"/> LS Lead Screw | Base-W × L | | | |

II \ Accessories :

- 1.Servo Motor : Brand _____ KW : _____ Type : _____
- 2.Motor Connect Way : Direct Coupled Motor Stand
 Coupling Timing Sprocket
- 3.Cylinder : Diameter _____ ∅ Travel _____ Fluid Control 1/4" 3/8"
 Standerd Type Stop Rod Back Drawing Type Stop Rod
 Back Type Stop Rod
- 4.Direction : Vertical ↓ _____ Horizontal ←→ _____ Side _____ Oblique □□ _____
- 5.Ball Screw : Diameter _____ ∅ Pitch _____ P Grade C _____ Single Nut
- 6.Lead Screw : Diameter _____ ∅ Pitch _____ P Double Nut
7. Front Extension Cover
8. Back Extension Cover
9. Front Fixed Cover
10. Back Fixed Cover
- 11.Others :

III \ Delivery Date : _____

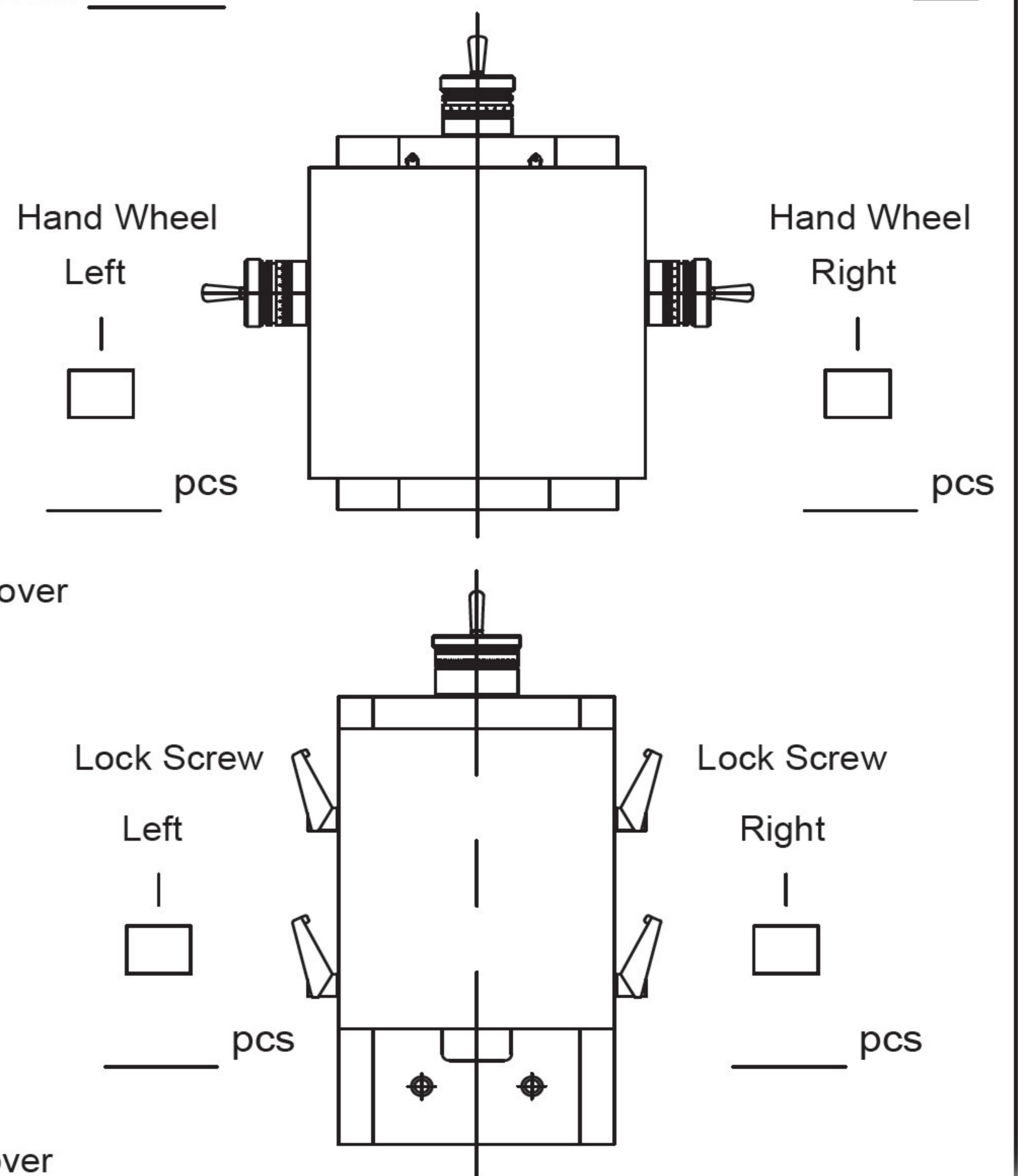
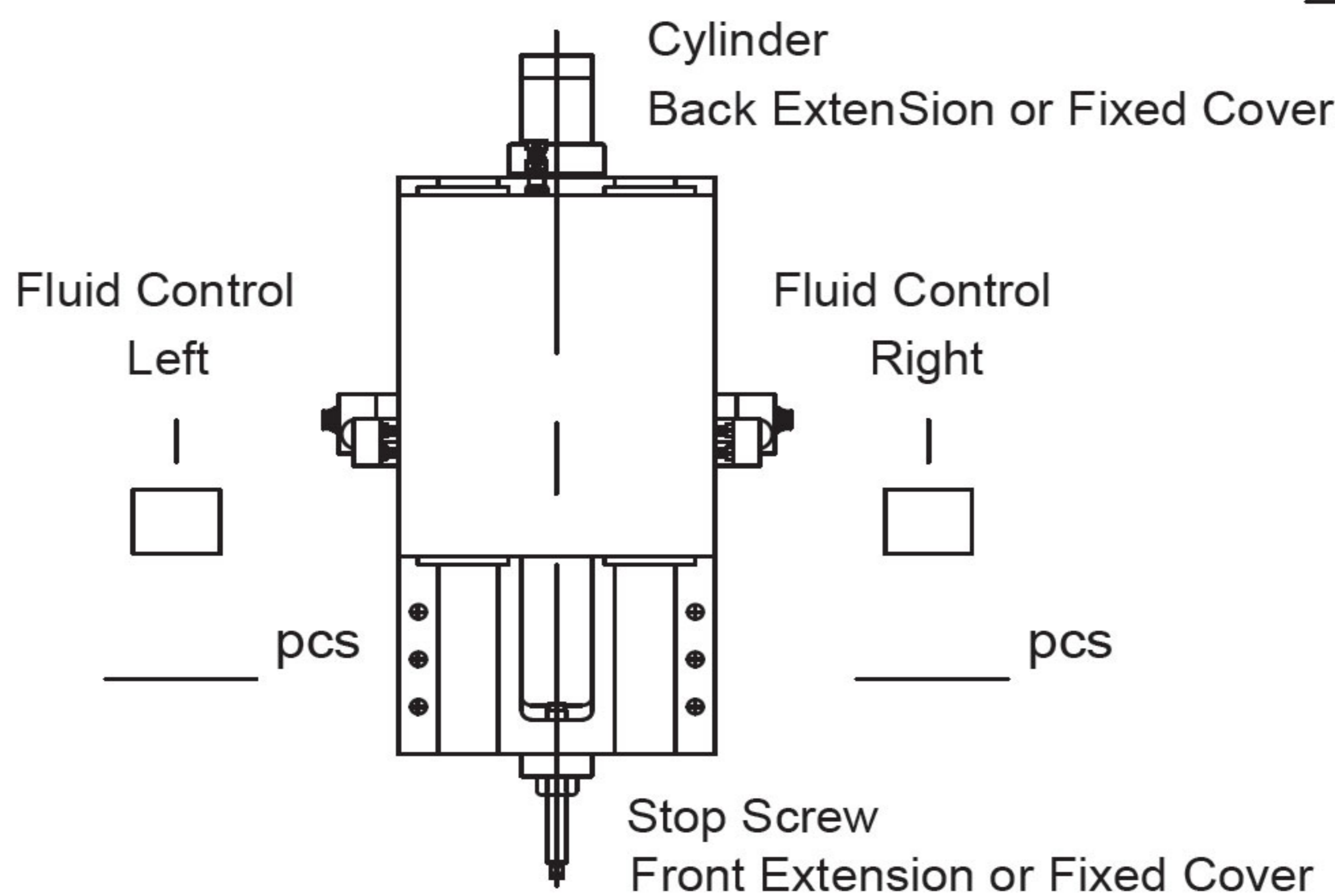

Authorised Distributors : Hann Kuen Machinery & Hardware Co., Ltd., Taiwan.



ISO 9001:2015 CERTIFIED COMPANY

F-343, Phase-V, Focal Point, Ludhiana - 141 010 Punjab, India
 Ph.: +91 161 5095142-43, +91 98550-09019
 Email: info@dolphinexports.com, mfg@dolphinexports.com
 www.dolphinexports.com

